

Clarke®

**Operator's
Manual**

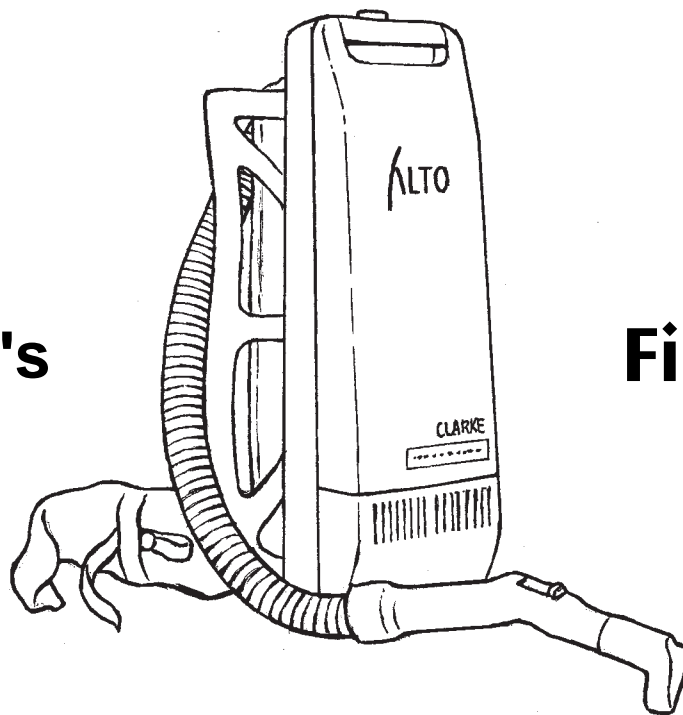

FiltraPac

READ THIS BOOK

This book has important information for the use and safe operation of this machine. Failure to read this book prior to operating or attempting any service or maintenance procedure to your Clarke machine could result in injury to you or to other personnel; damage to the machine or to other property could occur as well. You must have training in the operation of this machine before using it. If your operator(s) cannot read English, have this manual explained fully before attempting to operate this machine.

Si Ud. o sus operadores no pueden leer el Inglés, se hagan explicar este manual completamente antes de tratar el manejo o servicio de esta máquina.

All directions given in this book are as seen from the operator's position at the rear of the machine.

For new books write to: Clarke®, 2100 Highway 265, Springdale, Arkansas 72764.

Table of Contents

Operator Safety Instructions	3
Safety Information	4
Introduction & Machine Specifications	5
Grounding Instructions	6
Maintenance	7
How To Change The Filter Bag	7
How To Clean The Motor Filter	8

SECTION II Parts and Service Manual

Main Body Assembly Drawing	10
Main Body Assembly Parts List	11
Back Frame and Harness Assembly Drawing and Parts List	12
Hose, Wand and Tools Assembly Drawing and Parts List	13
Electrical Schematic	14

English *Correct Disposal of This Product (Waste Electrical & Electronic Equipment)*

(Applicable in the European Union and other European countries with separate collection systems)



This marking shown on the product or its literature, indicates that it should not be disposed with other household wastes at the end of its working life. To prevent possible harm to the environment or human health from uncontrolled waste disposal, please separate this from other types of wastes and recycle it responsibly to promote the sustainable reuse of material resources. Household users should contact either the retailer where they purchased this product, or their local government office, for details of where and how they can take this item for environmentally safe recycling.

Business users should contact their supplier and check the terms and conditions of the purchase contract. This product should not be mixed with other commercial wastes for disposal.



IMPORTANT SAFETY INSTRUCTIONS

When using an electrical appliance, basic precautions should be followed including the following: Read all instructions before using these appliances

 **WARNING**

 **AVERTISSEMENT**

 **ADVERTENCIA**

- | | |
|---|--|
|  DANGER: | Failure to read and observe all DANGER statements could result in severe bodily injury or death. Read and observe all DANGER statements found in your Owner's Manual and on your machine. |
|  WARNING: | Failure to read and observe all WARNING statements could result in injury to you or to other personnel; property damage could occur as well. Read and observe all WARNING statements found in your Owner's Manual and on your machine. |
|  CAUTION: | Failure to read and observe all CAUTION statements could result in damage to the machine or to other property. Read and observe all CAUTION statements found in your Owner's Manual and on your machine. |

 **WARNING:** To reduce the risk of fire, electric shock, or injury:

1. Do not leave appliance when plugged in. Unplug from outlet when not in use and before servicing.
2. Do not use outdoors or on wet surfaces.
3. Do not allow to be used as a toy. Close attention is necessary when used by or near children.
4. Use only as described in the manual. Use only manufacturer's recommended attachments.
5. Do not use with damaged cord or plug. If appliance is not working as it should, has been dropped, damaged, left outdoors, or dropped into water, return it to a service center.
6. Do not pull or carry by cord, use cord as a handle, close a door on cord, or pull cord around sharp edges or corners. Do not run appliance over cord. Keep cord away from heated surfaces.
7. Do not unplug by pulling on cord. To unplug, grasp the plug, not the cord.
8. Do not handle plug or appliance with wet hands.
9. Do not put any object into openings. Do not use with any opening blocked; keep free of dust, lint, hair and anything that may reduce air flow.
10. Keep hair, loose clothing, fingers, and all parts of body away from openings and moving parts.
11. Do not pick up anything that is burning or smoking, such as cigarettes, matches, or hot ashes.
12. Do not use without dust bag and/or filters in place.
13. Turn off all controls before unplugging.
14. Use extra care when cleaning on stairs.
15. Do not use to pick up flammable or combustible liquids such as gasoline or use in areas where they may be present.
16. Connect to properly grounded outlet. See "Grounding Instructions".

SAVE THESE INSTRUCTIONS

SAFETY INFORMATION

Information for your safety and notes on disposal

Before using the FiltraPac, please read the information below with care. This gives important guidance on the safety use and maintenance of the FiltraPac. Keep this booklet in a safe place, and if appropriate, hand it on to the next owner.

- This Clarke vacuum complies with recognized technological standards and the current safety regulations for electrical appliances.
- This appliance fulfills the requirements of EU guidelines 89/336/EEC (Electromagnetic compatibility) and 73/23/EEC (Low voltage guideline). The appliance is marked with the CE symbol on the rating plate for 230V models.

Clarke reserves the right to modify designs and specifications without notice.

Important Information

- Do not switch on the appliance if the housing exhibits any evidence of damage (cracks/fractures), if the connecting lead is defective, or if an internal defect is suspected (e.g. if the appliance has been dropped).
- Appliance only to be connected to voltage indicated on the rating plate.
- Clarke will not accept any liability for damage or injury if the appliance is used other than for its intended purpose or is improperly operated or inexpertly repaired and maintained.
- Before use, check to ensure that all the filters are correctly installed. The appliance must not be used without filters.
- Use only genuine Clarke filters and accessories.
- When connecting accessories, cleaning, repairing or servicing the unit, unplug the unit.
- Do not let children use electrical appliances unsupervised.
- This appliance is not suitable to be used to pick up substances constituting a health hazard.
- Repairs should be carried out by an authorized Clarke service center (see Operator's Manual for list of addresses). Incorrect repairs may expose the user to electrical danger.

- Any appliance used commercially is to be operated only by persons properly instructed in its use and operation.

Safety Precautions

- Do not pull out the plug from power supply socket by pulling on the connecting lead.
- Do not pull the connecting lead over sharp edges or allow it to become jammed.
- Do not use damaged extension leads.
- If required, the connecting lead has to be replaced together with the cable rewind by a specialist.
- Never replace the power supply cable with anything other than the same type of cable specified by the maker (H 05 VVF 2 x 0.75).
- The supply cable has to be replaced by an authorized Clarke After-Sales-Service only.
- Before any maintenance operation or replacing a filter, and after use, switch off the appliance and pull out the mains plug.
- Keep the nozzles and ends of tubes well away from the eyes and ears.
- The appliance must only be used for dry vacuum cleaning. It is not a dual purpose (wt/dry) vacuum cleaner.
- Do not use the appliance to pick up hot or glowing substances.
- Do not use the appliance to pick up coarse slivers of glass.
- Do not use the appliance to pick up any solvents, explosive liquids or gases.
- Do not store the appliance outdoors.
- Do not expose the machine to weather, humidity nor excessive heat.
- Clean the appliance only with a dry or slightly moist cloth. Do not allow any of the electrical components (switches, plug, socket, electronics, etc.) to come into contact with water.

INTRODUCTION

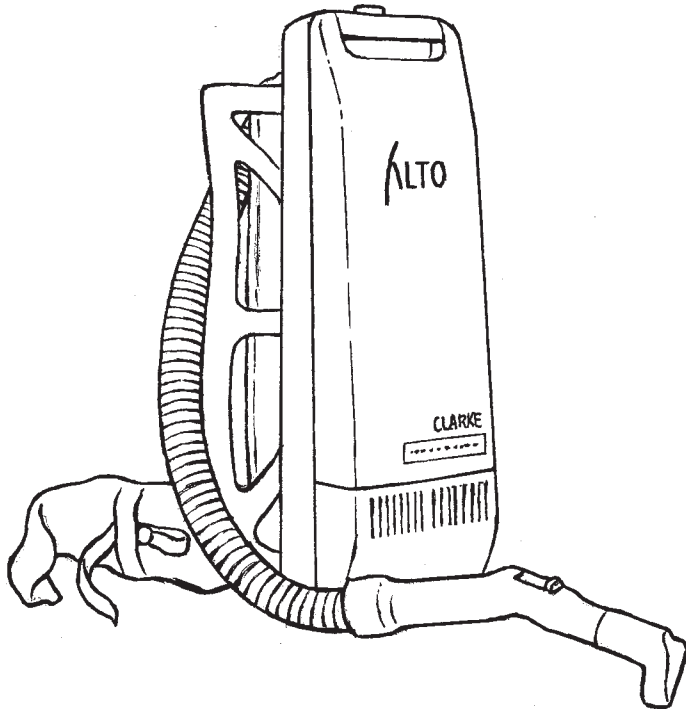

MACHINE SPECIFICATIONS

Model	Filtra-Pac 02150A
Power Supply	115V-60 Cycle
Vacuum Motor	19,200 rpm
Power Brush Motor	11,000 rpm
Cord	40 ft.
Wand Attachment	1 3/8" x 20 1/2" (2)
Hose	1 1/4" x 64"
Filter Bags	6 lt, 2-ply disposable
Weight	11.5 lbs.
Shipping Weight	17 lbs
Warranty	1 year

The FiltraPac is a vacuum for cleaning carpet. This machine is used to remove dry material from carpet. This machine is intended for commercial use.

OPTIONAL ACCESSORIES

Part No.	Description
52393A	Power Wand ¼ HP Perm. Magnet Mtr. 12"
50721B	Paper Filter Bag Pkg of 5
54025A	Micro-Staph Filter Pkg of 15
50747A	Cloth Filter Bag FiltraPac
59203A	Crevice Tool
59204A	Upholstery Tool
59206A	Soft Floor Tool
59978A	Hard Floor Tool (rep. brush #52395A)
59818A	Extension Wand (Plastic, 2 piece)
52838A	Airline 400 Cycle Conversion Kit
54490	Extension Wand (Aluminum, 2 piece)
47109	Telescoping Chrome Wand
5146	Swivel Dusting Brush
14295	4.5" Nozzle (Plastic)
5145	6" Nozzle (Aluminum)
6086	Brush 9" Plastic for Upholstery & Furniture
5144	Louver Brush Nozzle
8046	Combination Tool 11" Plastic (soft & hard floor)
5147	Metal Floor Tool 13.5" (rep. brush #5147)
54118	Turbine Brush - Vacuum Powered Carpet Tool
15348	Metal Floor Tool 18" (rep. brush #15351)

GROUNDING INSTRUCTIONS

This appliance must be grounded. If it should malfunction or breakdown, grounding provides a path of least resistance for electric current to reduce the risk of electric shock. This appliance is equipped with a cord having an equipment-grounding conductor and grounding plug. The plug must be plugged into an appropriate outlet that is properly installed and grounded in accordance with all local codes and ordinances.

⚠ WARNING: Improper connection of the equipment-grounding conductor can result in risk of electric shock. Check with a qualified electrician or service person if you are in doubt as to whether the outlet is properly grounded. Do not modify the plug provided with the appliance - if it will not fit the outlet, have a proper outlet installed by a qualified electrician.

This appliance is for use on a nominal 120-volt circuit and has a ground plug that looks like the plug illustrated in figure 1. Make sure that the appliance is connected to an outlet having the same configuration as the plug. No adapter should be used with this appliance.

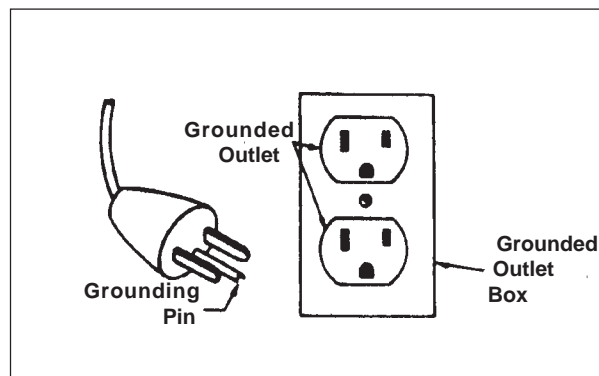

Figure 1

HOW TO USE THE MACHINE

How to Put the FiltraPac on and Adjust for Comfort

Follow these steps to put on the FiltraPac and to make adjustments for fitting comfort:

1. Pick up and put on vacuum, sliding in one arm at a time.
2. Buckle the waist belt.
3. To properly adjust the shoulder strap and belt harness, pull down on shoulder straps so the material slips through buckle until tight.
4. Tighten the waist belt. The waist belt should be very snug to transfer the weight to the hip and legs.
5. Practice the vacuuming technique using a side to side sweeping motion. See figure 2.
6. Use a twisting motion to install and remove the friction fit tools.
7. Take the vacuum off by first loosening both straps on the shoulder harness, then unbuckle belt harness.
8. Remove the pack.

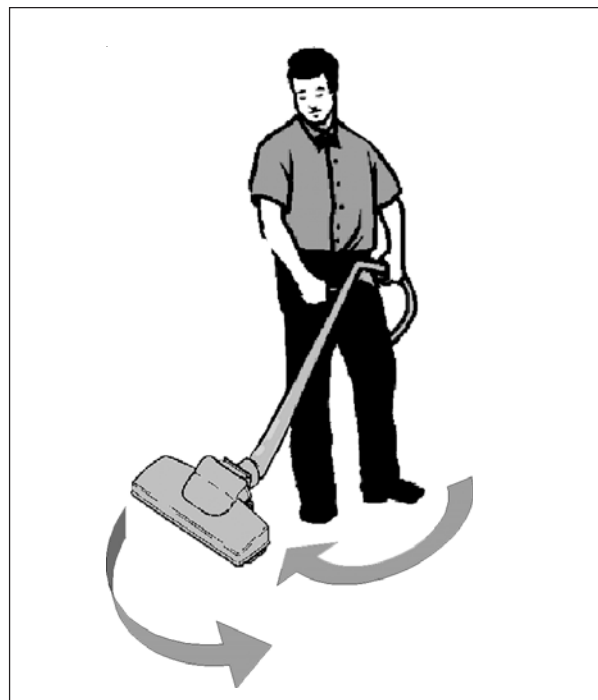

Figure 2

MAINTENANCE

⚠ WARNING: To prevent injury, always remove the electrical plug from the electrical outlet before doing any maintenance or repairs to the machine.

⚠ WARNING: Maintenance and repairs must be done by authorized personnel only. Use only genuine Clarke parts.

How To Change The Filter Bag

The machine uses a paper filter bag or a cloth filter bag. To change the paper filter bag, follow this procedure:

1. Make sure the ON/OFF switch in the "O" position.
2. Open the front of the tank housing. To open the tank housing, press the tank release bar. See figure 3.
3. Hold the bag by the cardboard inlet.
4. Pull the bag out.
5. Install a new filter bag. To install a new filter bag, follow this procedure:
 - a. Unfold the filter bag.
 - b. Hold the bag by the cardboard inlet.
 - c. Put the opening in the cardboard inlet over the bag adapter. See figure 4.
 - d. Close the tank housing.

To empty the cloth filter bag, follow this procedure:

1. Open the front of the tank housing.
2. Remove the cloth filter bag from the bag adapter.
3. Slide the clamp off the filter bag. See figure 5.
4. Remove the dirt from the bag.
5. Slide the clamp on the bottom of the filter bag.
6. Install the filter bag in the machine.
7. Close the tank housing.

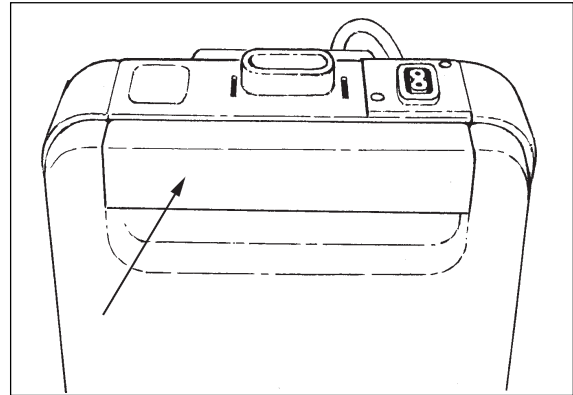

Figure 3

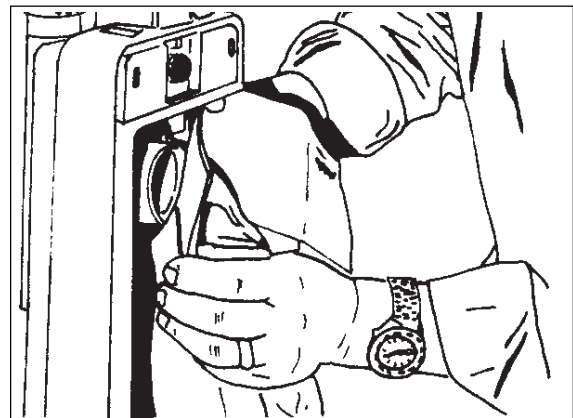

Figure 4

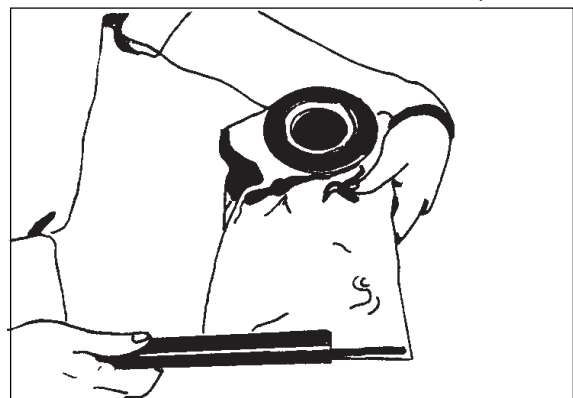

Figure 5

MAINTENANCE

How To Clean The Motor Filter

Clean the motor filter whenever it is dirty. To clean the motor filter, follow this procedure:

1. Open the tank assembly.
2. Remove the filter bag.
3. Pull the filter cover off the filter disc.
4. Remove the filter.
5. Wash the filter in water.
6. Put the filter in a cloth and apply pressure to dry the filter.
7. Put the filter in the filter cover.

NOTE: Install the filter cover with the opening toward the back of the tank housing. See figure 6.

CAUTION: Check the motor protection filter while changing the paper bag. Please change the motor protection filter after use of 6 paper bags.

8. Install the filter bag.
9. Close the tank assembly.

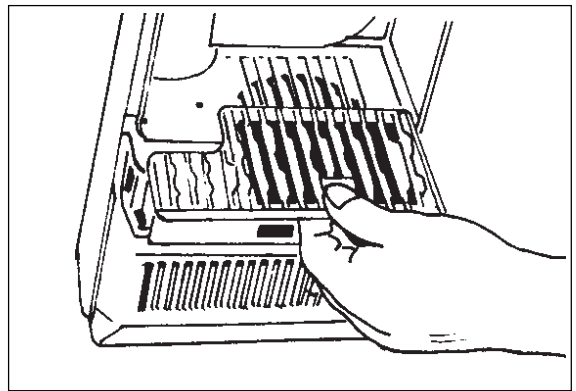

Figure 6

Clarke[®]

FiltraPac

Section II
Parts and Service Manual

(70290A)

Clarke®
 FiltraPac
 Main Body
 Assembly Drawing 7/01

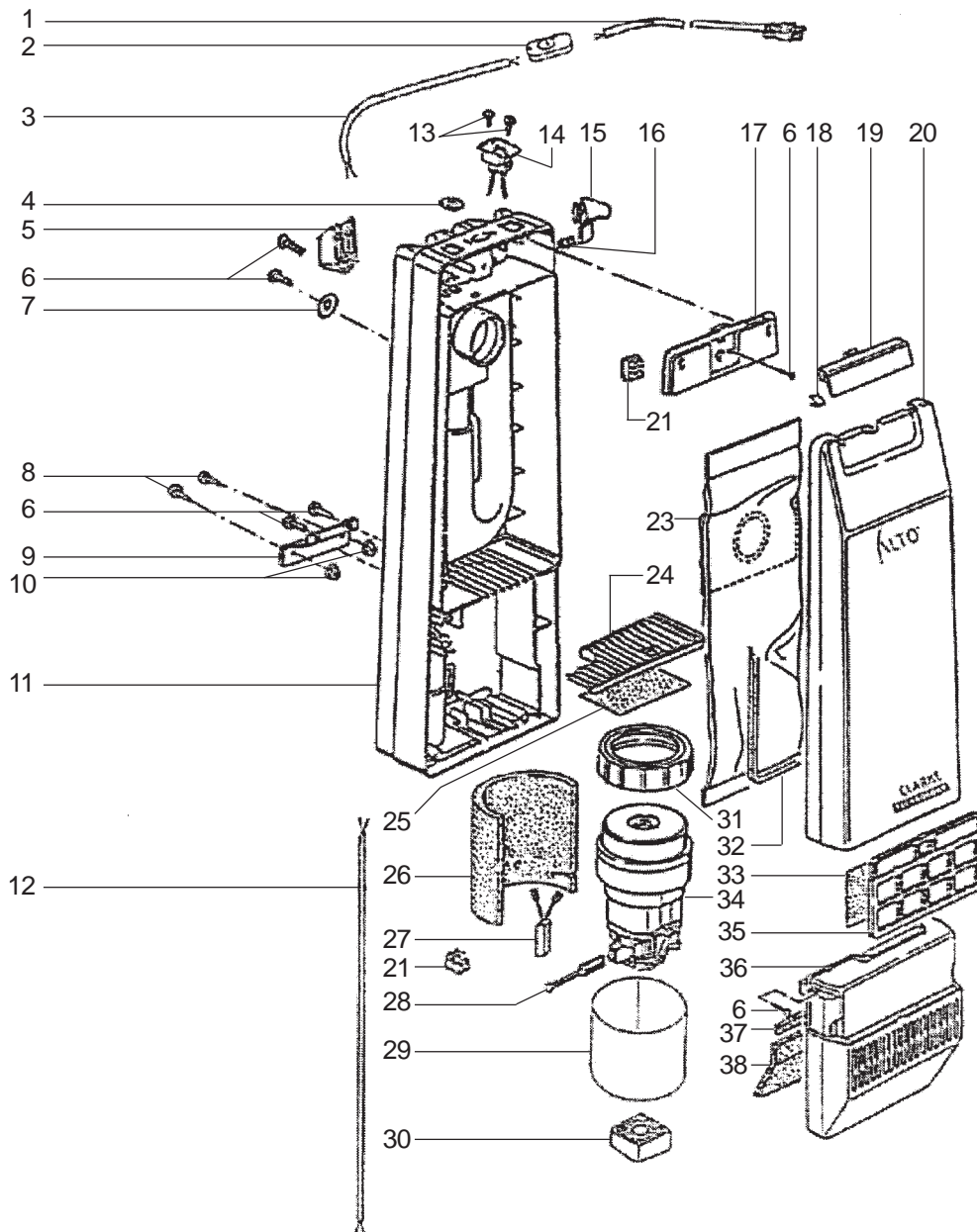

Clarke®
FiltraPac
Main Body
Assembly Drawing Parts List 1/05

Ref.	Part #	Description	Qty.
1	52370A	Power Cord only	1
2	52371A	Switch only	1
3	52372A	Power Cord w/Switch	1
4	52373A	Cover Washer	1
5	52374A	Strain Relief	1
6	57951A	Screw 4mm x 20	8
7	52375A	Washer	8
8	964004	Screw, 5mm x .8 x 16mm	2
9	52376A	Angle Bracket	1
10	52377A	Nut 4mm	2
11	52378A	Rear Canister	1
12	52379A	Flat Cable	1
13	80067A	Screw 3mm x 12	2
14	52380A	Socket, Receptacle	1
15	55658A	Bar, Locking	1
16	58693A	Spring, Spiral	1
17	52381A	Cover Plate	1
18	53408A	Spring	1
19	55715B	Latch	1
20	52906B	Cover, Canister	1
21 ♦	50636A	Terminal Block	1
22			
23	50721B	Bag, Paper 10 Pak	1
	50447A	Cloth Filter Bag (Optional)	1
24	54023A	Filter Frame	1
25	54024A	Filter, Motor	1
26	54734A	Insulating Insert	1
27	52382A	Overheat Cutout	1
28	52383A	Carbon Brush w/Holder	2
29	43607A	Insulation, Motor	1
30	52384A	Motor Bearing Block	1
31	57862A	Motor Gasket Seal	1
32	54360A	Gasket, Canister Front	1
33	54025A	Filter, Micro Exhaust	1
34	52385A	Vac Motor 120 Volt	1
35	54026A	Filter Cassette	1
36	52386A	Motor Cover	1
37	54361A	Gasket Strip	1
38	53931A	Foam Insulation	1
NI	53394A	H.E.P.A. Filter (Optional)	1

NOTE: ♦ indicates a change has been made since the last publication of this manual.

Clarke®
FiltraPac
Back Frame and Harness
Assembly Drawing and Parts List 7/01

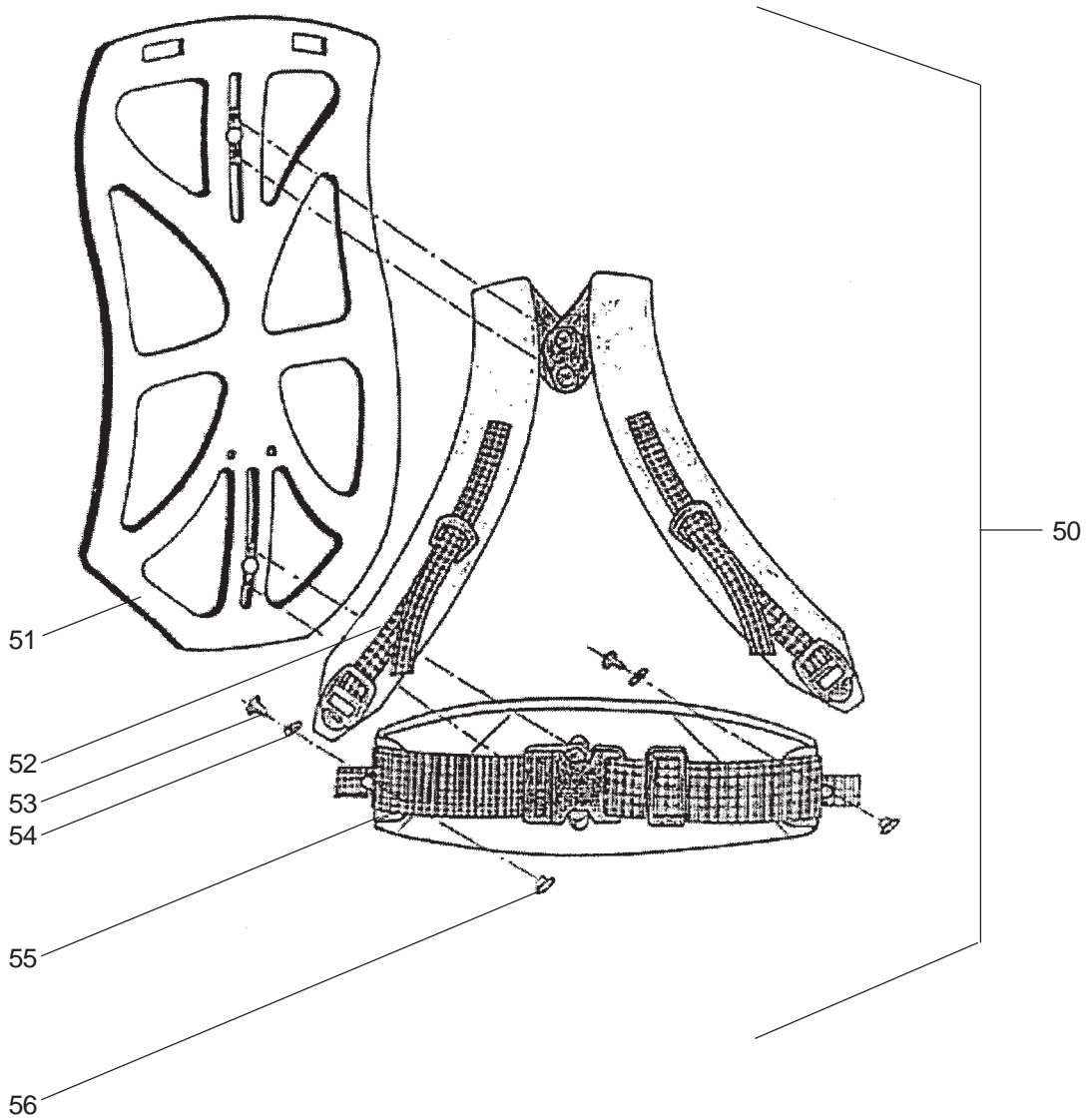

Ref.	Part #	Description	Qty.
50	52387A	Carry Frame Complete	1
51	52388A	Carry Frame	1
52	52389A	Shoulder Strap	1
53	52390A	Rivet	4
54	980205	Washer	2
55	52391A	Waist Belt	1
56	52394A	RivetNut	4

**Clarke®
FiltruPac
Hose, Wand and Tools
Assembly Drawing Parts List 1/05**

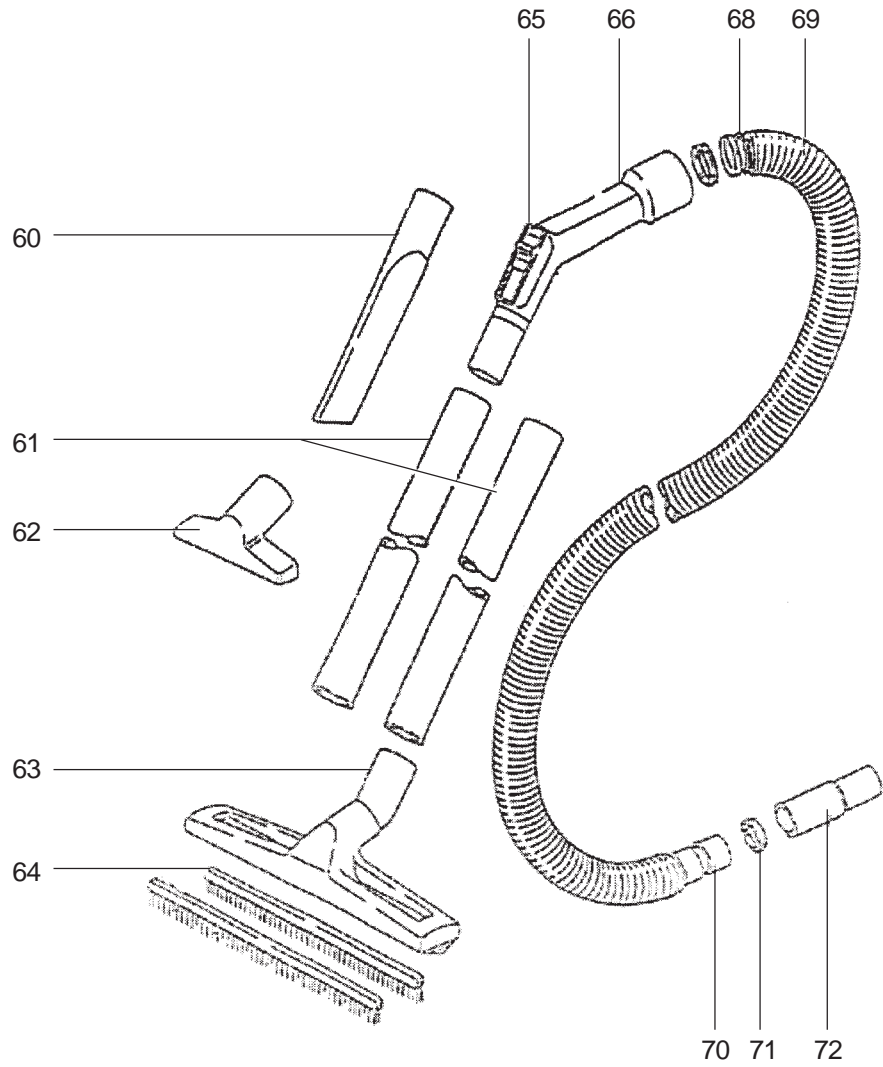

Ref.	Part #	Description	Qty.
60	59203A	Crevice Tool	1
61	54490	Wand - 2 Piece	1
62	59204A	Nozzle Upholstery	1
63	59206A	Soft Floor Tool	1
	59978A	Hard Floor Tool	0
64	52395A	Bristle Set	0
65◆	52478A	Regulating Slide	1
66◆	61447A	Hand Tube	1
68◆	52479A	Connecting Socket	1
69◆	10372A	Hose & Handle Asm.	1
70	53054A	Swivel End, Hose	1
71	57405A	Retainer, Spring	1
72	53075A	Socket, Connecting	1

NOTE: ◆ indicates a change has been made since the last publication of this manual.

Clarke®
FiltraPac
Electrical Schematic 11/04

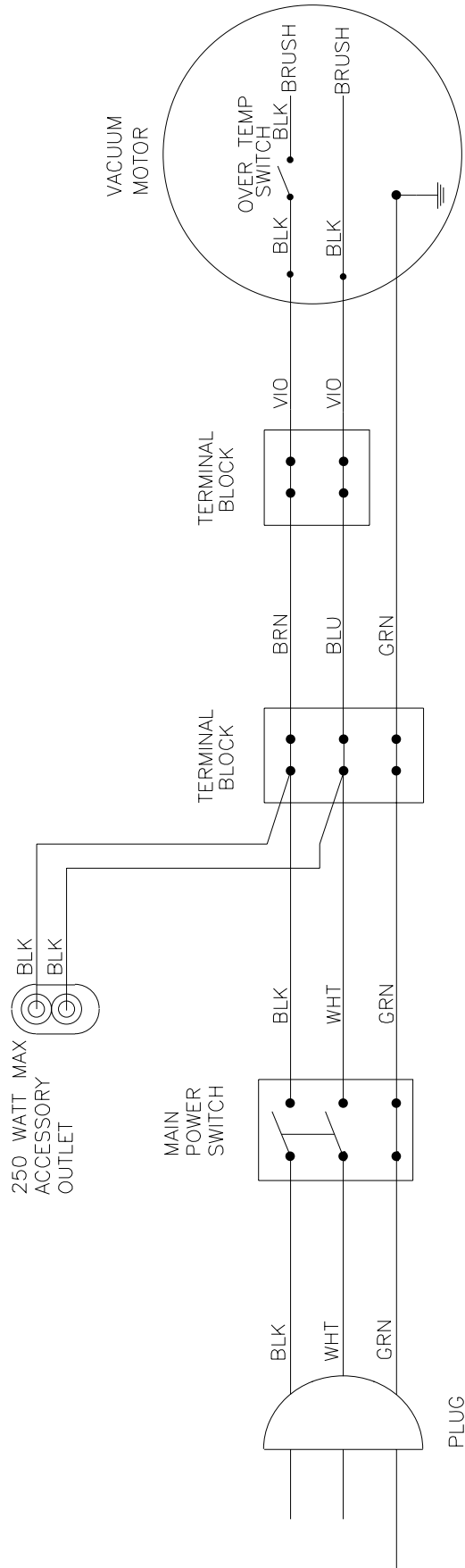

CLARKE PRODUCT SUPPORT BRANCHES

U. S. A. Locations

PRODUCTION FACILITIES

Clarke®, Springdale, Arkansas
2100 Highway 265
Springdale, Arkansas 72764
(479) 750-1000
Customer Service - 1-800-253-0367
Technical Service - 1-800-356-7274

American Lincoln®, Bowling Green, Ohio 43402
1100 Haskins Road

SERVICE FACILITIES

Clarke®, Elk Grove, Illinois 60007
2280 Elmhurst Road
(847) 956-7900

Clarke®, Denver, Colorado 80204
1955 West 13th Ave.
(303) 623-4367

Clarke®, Houston, Texas 77040
7215 North Gessner Road
713-937-7717

SERVICE AND SALES FACILITY

American Lincoln® / Clarke, Madison Heights,
Michigan 48071-0158
29815 John R.
(810) 544-6300

American Lincoln® / Clarke, Marietta, Georgia 30066
1455 Canton Road
(770) 973-5225

Clarke®

Clarke American Sanders

A.L. Cook

Customer Service Headquarters and Factory
2100 Highway 265
Springdale, Arkansas 72764
(479) 750-1000

Technical Service
1-800-356-7274

European Locations

PRODUCTION FACILITIES

ALTO Danmark A/S, Aalborg
Blytaekkervej 2
DK-9000 Aalborg
+45 72 18 21 00

ALTO Danmark A/S, Hadsund
Industrikarveret
DK-9560 Hadsund
+45 72 18 21 00

SALES SUBSIDIARIES

ALTO US - Canada, Ontario (Canada)
4080 B Sladeview Crescent Unit 1
Mississauga, Ontario L5L 5Y5
(905) 569 0266

ALTO Overseas Inc., Sydney (Australia)
1B/8 Resolution Drive
Caringbah NSW 2229
+61 2 9524 6122

ALTO Cleaning Systems Asia Pte Ltd., Singapore
No. 17 Link Road
Singapore 619034
+65 268 1006

ALTO Deutschland GmbH, Bellenberg (Germany)
Guido-Oberdorfer-Straße 2-8
89287 Bellenberg
+49 0180 5 37 37 37

ALTO Cleaning Systems (UK) Ltd., Penrith
Gilwilly Industrial Estate
Penrith
Cumbria CA11 9BN
+44 1768 868 995

ALTO France S.A. Strasbourg
B.P. 44, 4 Place d'Ostwald
F-67036 Strasbourg
Cedex 2
+33 3 8828 8400

ALTO Nederland B.V.
Postbus 65
3370 AB Hardinxveld-Giessendam
The Netherlands
+31 184 677 200

ALTO Sverige AB, Molndal (Sweden)
Aminogatan 18
Box 4029
S-431 04 Molndal
+46 31 706 73 00

ALTO Norge A/S, Oslo (Norway)
Bjornerudveien 24
N-1266
+47 2275 1770

Clarke® U.S. LIMITED WARRANTY

This Clarke Industrial/Commercial Product is warranted to be free from defects in materials and workmanship under normal use and service for a period of one year from the date of purchase, when operated and maintained in accordance with Clarke's Maintenance and Operations Instructions.

This warranty is extended only to the original purchaser for use of the product. It does not cover normal wear parts such as electrical cable, rubber parts, hoses and motor brushes.

If a difficulty develops with the product, you should:

(a). Contact the nearest authorized Clarke repair location or contact the Clarke Service Operations Department, 2100 Highway 265, Springdale, Arkansas 72764, for the nearest authorized Clarke repair location. Only these locations are authorized to make repairs to the product under this warranty.

(b). Return the product to the nearest Clarke repair location. Transportation charges to and from the repair location must be prepaid by the purchaser.

(c). Clarke will repair the product and/or replace any defective parts without charge within a reasonable time after receipt of the product.

Clarke's liability under this warranty is limited to repair of the product, and/or replacement of parts and is given to purchaser in lieu of all other remedies, including INCIDENTAL AND CONSEQUENTIAL DAMAGES.

THERE ARE NO EXPRESS WARRANTIES OTHER THAN THOSE SPECIFIED HEREIN. THERE ARE NO WARRANTIES WHICH EXTEND BEYOND THE DESCRIPTION OF THE FACE HEREOF. NO WARRANTIES, INCLUDING BUT NOT LIMITED TO WARRANTY OF MERCHANTABILITY, SHALL BE IMPLIED. A warranty registration card is provided with your Clarke product. Return the card to assist Clarke in providing the performance you expect from your new floor machine.

Clarke®, 2100 Highway 265, Springdale, Arkansas 72764.

Clarke reserves the right to make changes or improvements to its machine without notice.

Always use genuine Clarke Parts for repair.

Clarke®

**2100 Highway 265
Springdale, Arkansas, 72764**