

Clarke®

Operator's Manual

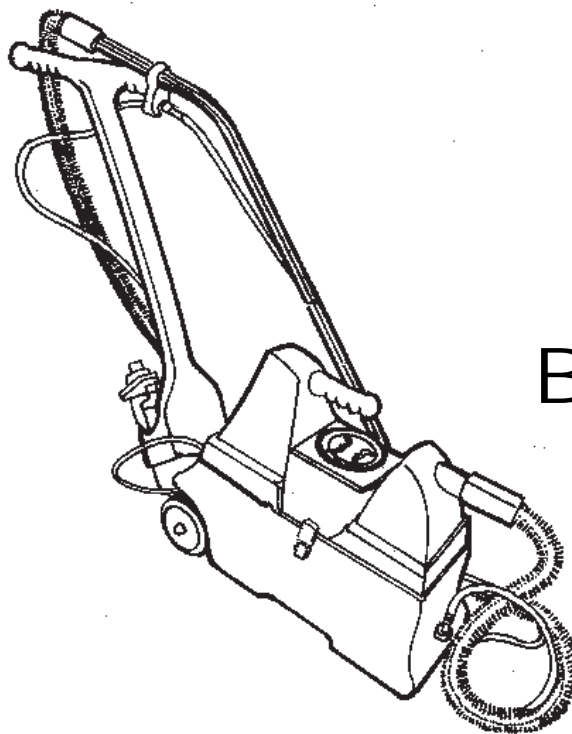

BEXTSPOT™

READ THIS BOOK

This book has important information for the use and safe operation of this machine. Failure to read this book prior to operating or attempting any service or maintenance procedure to your Clarke machine could result in injury to you or to other personnel; damage to the machine or to other property could occur as well. You must have training in the operation of this machine before using it. If you or your operator(s) cannot read English, have this manual explained fully before attempting to operate this machine.

Si Ud. o sus operadores no pueden leer el Inglés, se hagan explicar este manual completamente antes de tratar el manejo o servicio de esta máquina.

All directions given in this book are as seen from the operator's position at the rear of the machine.

For new books write to: Clarke®, 2100 Highway 265, Springdale, Arkansas 72764.

Table of Contents

Operator Safety Instructions	3
Grounding Instructions	4
How To Prepare the Machine for Operation	5
Operating The Machine	6
Shut Down and Daily Maintenance	6
How to Correct Problems in the Machine	7
Assembly Drawing	8
Parts List	9
Tool Assembly Drawing and Parts List	10
Vacuum and Solution Hose Drawing and Parts List	11
Authentic Clarke Products	12
Wiring Diagram	13

SPECIFICATIONS

Part Number	04153A
Solution Pump	55 PSI
Power Cable	18/3 SJTW Hospital Grade Plug 25 ft.
Solution Tank	2 gallons
Recovery Tank	2.5 gallons
Hose Length	10 ft. x 1.25 in.
Waterlift	85"
Vacuum	Peripheral Discharge 1.25 HP, 2 Stage
Electrical	120 Volt 50/60 Hz
Dimensions	25" x 19" x 10.5"
Weight	24.5 lbs.
Shipping Weight	30 lbs.

10592A Deluxe Kit includes the following:

- 53395A - Handle
- 52955B - Starter Kit
- 59230A - Tool, Floor Wand

OPERATOR SAFETY INSTRUCTIONS



WARNING



AVERTISSEMENT



ADVERTENCIA



DANGER:

Failure to read and observe all **DANGER** statements could result in severe bodily injury or death. Read and observe all **DANGER** statements found in your Owner's Manual and on your machine.



WARNING:

Failure to read and observe all **WARNING** statements could result in injury to you or to other personnel; property damage could occur as well. Read and observe all **WARNING** statements found in your Owner's Manual and on your machine.



CAUTION:

Failure to read and observe all **CAUTION** statements could result in damage to the machine or to other property. Read and observe all **CAUTION** statements found in our Owner's Manual and on your machine.



WARNING: To reduce the risk of fire, electric shock or injury:

1. Do not leave appliance unattended when plugged in. Unplug from outlet when not in use and before servicing.
2. To reduce the risk of electric shock use indoors only.
3. Do not allow to be used as a toy. Close attention is necessary when using by or near children.
4. Use only as described in the manual. Use only manufacturer's recommended attachments.
5. Do not use with damaged cord or plug. If appliance is not working as it should, has been dropped, damaged, left outdoors, or dropped in water, return it to a service center.
6. Do not pull or carry by cord, use cord as a handle, close a door on cord, or pull cord around sharp edges or corners. Do not run appliance over cord. Keep cord away from heated surfaces.
7. Do not unplug by pulling on cord. To unplug, grasp the plug, not the cord.
8. Do not handle plug or appliance with wet hands.
9. Do not put any object into openings. Do not use with any opening blocked; keep free of dust, lint, hair and anything that may reduce air flow.
10. Keep hair, loose clothing, fingers, and all parts of body away from openings and moving parts.
11. Do not pick up anything that is burning or smoking, such as cigarettes, matches or hot ashes.
12. Do not use without filters in place.
13. Turn off all controls before operating.
14. Use extra care when cleaning on stairs.
15. Do not use to pick up flammable or combustible liquids such a gasoline or use in areas where they may be present.
16. Connect to properly grounded outlet. See "Grounding Instructions".



WARNING:

Any alterations or modifications of this machine could result in damage to the machine or injury to the operator or other bystanders. Alterations or modifications not authorized by the manufacturer voids any and all warranties and liabilities.

- ⚠ WARNING:** Do not operate this unit in standing water. This may result in electrical shock which could cause severe personal injury or fatality.
- ⚠ WARNING:** Operating this unit without it completely assembled could result in injury. Do not operate this unit unless it is completely assembled.
- ⚠ WARNING:** Do not touch electrical wires or components while this unit is running or connected to electrical outlet. They can be sources of electrical shock.
- ⚠ WARNING:** Do not expose this unit to freezing weather. If freezing occurs, thaw completely. Always protect your portable cleaning unit from freezing. Freezing will void the warranty.
- ⚠ WARNING:** Use standard cleaning chemicals with this equipment. NEVER use solvents.
- ⚠ WARNING:** DO NOT use this unit as a dry vacuum. This unit is not equipped with a dust filtration system. The dust may damage the vacuum motor(s).
- ⚠ WARNING:** DO NOT attempt repairs. Unauthorized or improper maintenance will void the warranty. Repairs should only be done by an authorized service center.
- ⚠ WARNING:** Always use defoamer if foaming occurs. Foam will suspend large particles which may damage vacuum(s), as well as allow liquid into the vacuum motor(s) without activating the float shutoff.

Grounding Instructions 120V Machines

Follow the instructions below for connection to the power supply and the electrical ground.

This product must be grounded . If it should malfunction or breakdown, grounding provides a path of least resistance for electric current to reduce the risk of electric shock. This product is equipped with a cord having an equipment-grounding conductor and grounding plug. The plug must be inserted into an appropriate outlet that is properly installed and grounded in accordance with all local codes and ordinances.

- ⚠ WARNING:** Improper connection of the equipment-grounding conductor can result in a risk of electric shock. Check with a qualified electrician or service person if you are in doubt as to whether the outlet is properly grounded. Do not modify the plug provided with the product. If it will not fit the outlet, have a proper outlet installed by a qualified electrician.

- ⚠ WARNING:** DO NOT remove the ground prong from your power cord. This could result in serious injury or fatality.

This product is for use on a nominal 120 volt circuit and has a grounding attachment plug that looks like the plug illustrated in Figure 1. Make sure that the product is connected to an outlet having the same configuration as the plug. No adapter should be used with this product.

- ⚠ WARNING:** DO NOT use an extension cord with this unit.

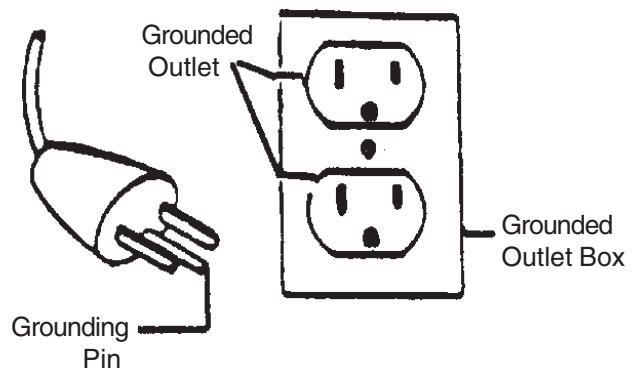

Figure1

How To Prepare the Machine For Operation

Before using this machine check the following:

1. Check all fittings and connectors for proper assembly.
2. Check all hoses for leaks. Repair or replace any damaged hoses.
3. Check power cord for any damage. If damaged, replace.

Filling the machine:

1. Fill the solution tank with clean hot or cold water.



WARNING: Do not use water that is hotter than 140°

2. Use only brand name cleaner and mix the cleaner per package instructions

Water Pump

Turn the pump switch ON. This pump is a by pass pump and operates continuously.

Vacuum (see figure 2)

1. Be sure access lid is on vacuum tank.
2. Make sure the latches connecting the vacuum tank and the solution tank are secure.
3. Turn switch ON.

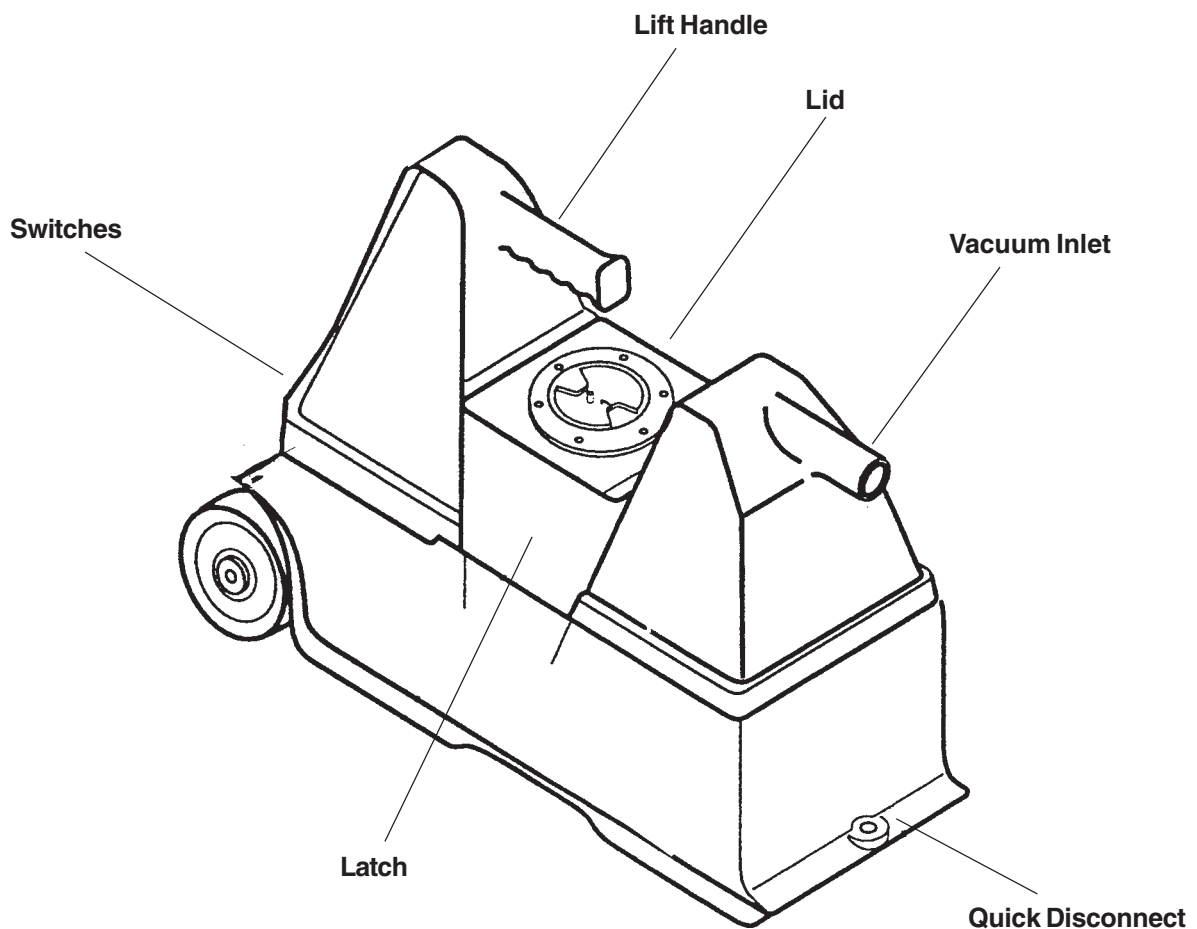



Figure2

Operating the Machine

Observe the following guidelines, while cleaning:

 **WARNING: Always use defoamer if foaming occurs. Foam will suspend large particles which may damage vacuum(s), as well as allow liquid into the vacuum motor(s).**

1. Before proceeding, make certain that the nozzle is functioning properly.
 - a. To check, hold the hand tool about one foot above the surface to be cleaned and open the hand tool valve. A full spray should be observed from the cleaning nozzle.
 - b. If the nozzle is not showing a full spray pattern, adjust nozzle for proper pattern, clean, or replace nozzle.
2. Normally, chemical is applied on the push stroke of the hand tool when cleaning. Vacuuming is done on the pull stroke. For heavily soiled carpets the hand tool may be used in a scrubbing manner, applying chemical in both push and pull strokes. Always finish up an area with a vacuum pull stroke.
3. When cleaning, keep the working opening (hand tool mouth) flat on the surface being cleaned. Keep the hand tool moving when the valve is open.

 **WARNING: Improper discharge of waste may damage the environment and be illegal. The United States Environmental Protection Agency has established certain regulations regarding discharge of waste water. Also, city and state regulations regarding the discharge may be in effect in your area. Understand and follow the regulations in your area. Be aware of the environmental hazards of chemicals that you dispose.**

Shut Down and Daily Maintenance

Shut Down Procedures

For shut down and daily maintenance, follow these procedures:

1. Turn "OFF" pump and vacuum switch.
2. Unplug power cord from outlet
3. Disconnect hand tool.
4. Open access lid. Pour contents into a five gallon pail or toilet.

NOTE: We recommend removing as much moisture from your vacuum hose as is possible. This will prevent spillage of solution.

5. Unhook the cleaning tool, solution hose, and vacuum hose.
6. Empty the recovery tank by removing the access lid from the vacuum tank and pouring the contents into a five gallon pail or toilet. Dispose of the waste in a proper manner.
7. Remove any debris or sediment which may have accumulated inside the recovery tank.
8. Place the access lid back on the recovery tank.

Daily Maintenance Procedures

If properly maintained, this unit will have a long and trouble-free life. We recommend that you make these maintenance procedures a part of your daily work schedule.

 **CAUTION: Unplug power cord before servicing or making any repairs.**

1. Inspect the power cord daily for any sign of damage. If damaged, replace the cord.
2. Inspect the solution hose daily for any damage. If the hose shows any signs of damage or impending rupture, replace the hose.

 **CAUTION: DO NOT attempt to repair hoses. Repairing high pressure hoses may result in severe burns and serious injury.**

3. Inspect the vacuum hose daily for any damage, breaks, or tears. Repair or replace the hose, if necessary.
4. Check spray tips daily. Clean spray tips, if plugged.
5. Monthly or as often as necessary, clean out any debris which may be in the vacuum tubing and hose.

HOW TO CORRECT PROBLEMS IN THE MACHINE

⚠ WARNING: Maintenance and repairs must be done by authorized personnel only. Use only Clarke parts. Maintenance performed by someone other than a Clarke distributor or Clarke replacement parts could void your warranty.

Electrical System

PROBLEM	CAUSE	ACTION
No electrical power.	<ol style="list-style-type: none"> 1. House or building circuit breaker tripped... 2. Defective power cord... 	<ol style="list-style-type: none"> 1. Reset circuit breaker. 2. Contact an authorized service person.
Switch is turned on. Power is intermittent to all motor(s).	<ol style="list-style-type: none"> 1. Faulty electrical cable... 2. Defective switches... 3. Loose terminal or discolored terminal connections... 	<ol style="list-style-type: none"> 1. Contact an authorized service person. 2. Replace Switch 3. Contact an authorized service person.

Vacuum System

PROBLEM	CAUSE	ACTION
No vacuum.	<ol style="list-style-type: none"> 1. Loose vacuum hose or loose vacuum connection... 	<ol style="list-style-type: none"> 1. Secure hose connections
Low vacuum.	<ol style="list-style-type: none"> 1. Defective vacuum hose... 2. Loose connection to the vacuum motor(s)... 	<ol style="list-style-type: none"> 1. Repair or replace hose. 2. Secure connections

Solution System

PROBLEM	CAUSE	ACTION
Pump motor on, no spray thru accessory tool(s).	<ol style="list-style-type: none"> 1. Clogged spray tips. 2. Punctured pump diaphragm... 3. Crack in pump housing. 	<ol style="list-style-type: none"> 1. Clean spray tips 2. Contact an authorized service person. 3. Contact an authorized service person.
Uneven or weak spray	<ol style="list-style-type: none"> 1. Clogged or dirty spray tips... 	<ol style="list-style-type: none"> 1. Clean or replace spray tips.
Vacuum motor(s) working, pump motor fails to turn on.	<ol style="list-style-type: none"> 1. Loose plug connector. Loose wiring connection... 2. Defective pump motor... 	<ol style="list-style-type: none"> 1. Check connections and tighten if necessary. 2. Contact an authorized service person.

Clarke®
BEXTSPOT™
Assembly Drawing 11/04

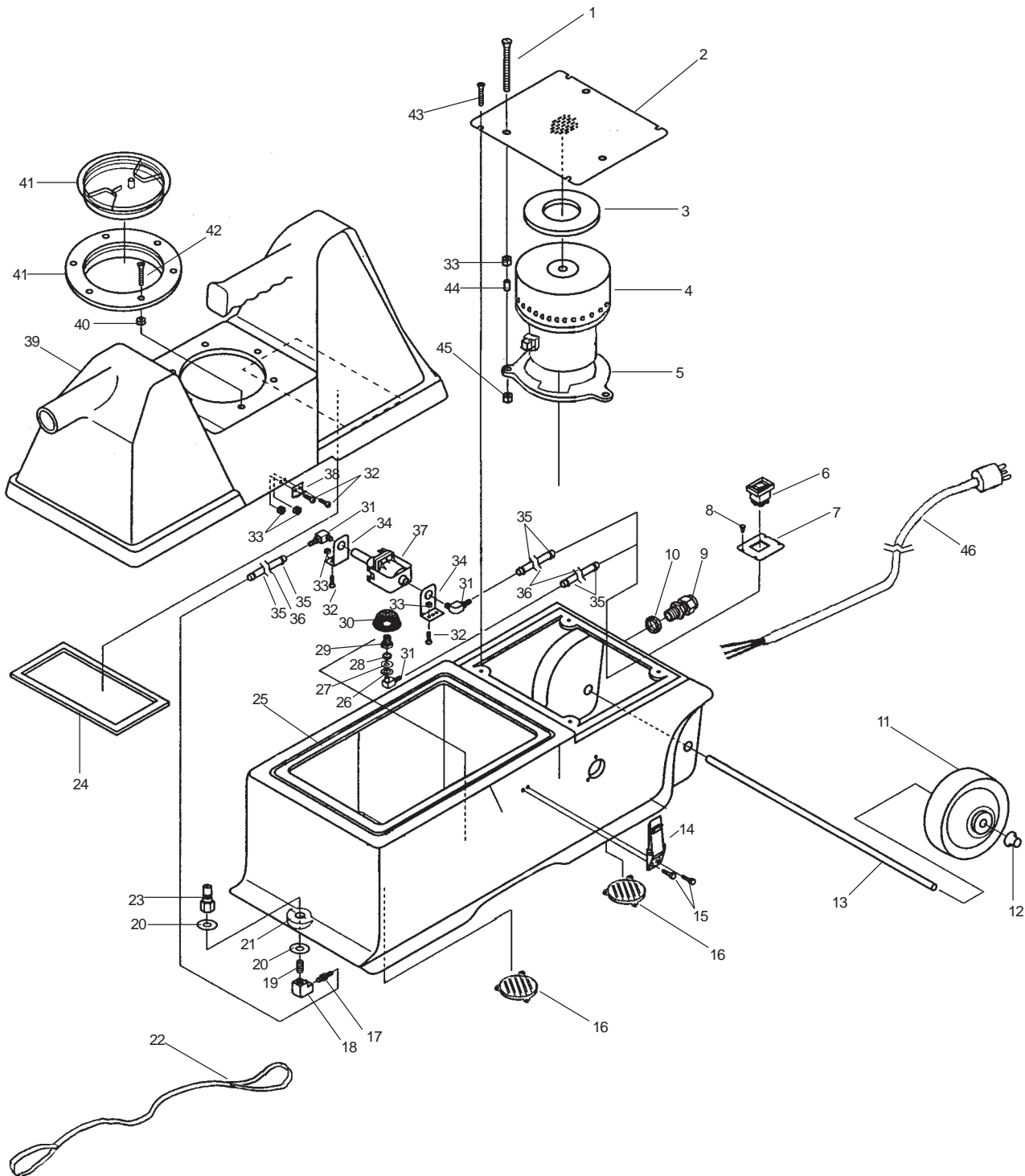

Clarke®
BEXTSPOT™
Assembly Parts List 11/04

Ref.	Part No.	Description	Qty
1	80258A	Bolt, 10-32 x 4 F.H.	3
2	61385A	Plate, Vacuum Mtg.	1
3	30485A	Gasket, Vac Motor	1
4	40669A	Motor, Vacuum 2 Stage	1
5	61386A	Clamp, Vac Motor	1
6	40670A	Switch, On/Off	1
7	61387A	Plate, Switch	1
8	80259A	Screw, Switch Plate	4
9	56459A	Strain, Relief	1
10	170686	Nut, Strain Relief	1
11	39857A	Wheel, 5"	2
12	61388A	Cap, Axle	2
13	61389A	Axle, 11.5" Rod	1
14	61390A	Latch, BextSpot	2
15	85609A	Screw, 10-32 x 3/8	4
16	61392A	Louver, BextSpot	2
17	54053A	Hose Barb, 1/4" Hose x 1/8" P.T.	1
18	69280A	Elbow	1
19	725729	Nipple, 1/8" P.T.	1
20	80260A	Washer, Brass	2
21	61392A	Base, Solution Tank	1
22	61468A	Strap, Transport	1
23	737140	Quick Disconnect 1/8" P.T.	1
24	30490A	Gasket, Recovery Tank	1
25	30486A	Gasket, Solution Tank	1
26	80261A	Washer, Flatt SS	1
27	80262A	Washer, Rubber	1
28	80263A	Nut, Brass 1/8" P.T.	1
29	61462A	Bushing, Brass	1
30	30488A	Filter, 40 Mesh	1
31	30487A	Elbow & Hose Barb	2
32	85616A	Screw, 10-32 x 5/8	8
33	920722	Locknut, 10-32	8
34	61464A	Bracket, Pump	2
35	61463A	Hose Clamp	6
36	30489A	Hose, 1/4" Braided	32 in.
37	40671A	Pump, 55 P.S.I.	1
38	61465A	Keeper, Latch	2
39	61466A	Tank, Recovery	1
40	80264A	Locknut, 8-32	6
41	61467A	Lid, Access	1
42	85613A	Screw, 8-32 x 7/8	6
43	80265A	Screw, 10-32 x 5/8 F.H.	4
44	30491A	Spacer, 1" Teflon	3
45	920722	Locknut, 10-32	6
46◆	40756A	Power Cord, 18-3 SJTW, 25'	1

NOTE: ◆ indicates a change has been made since the last publication of this manual.

Clarke®
BEXTSPOT™
Tool Assembly
Drawing and Parts List 11/03

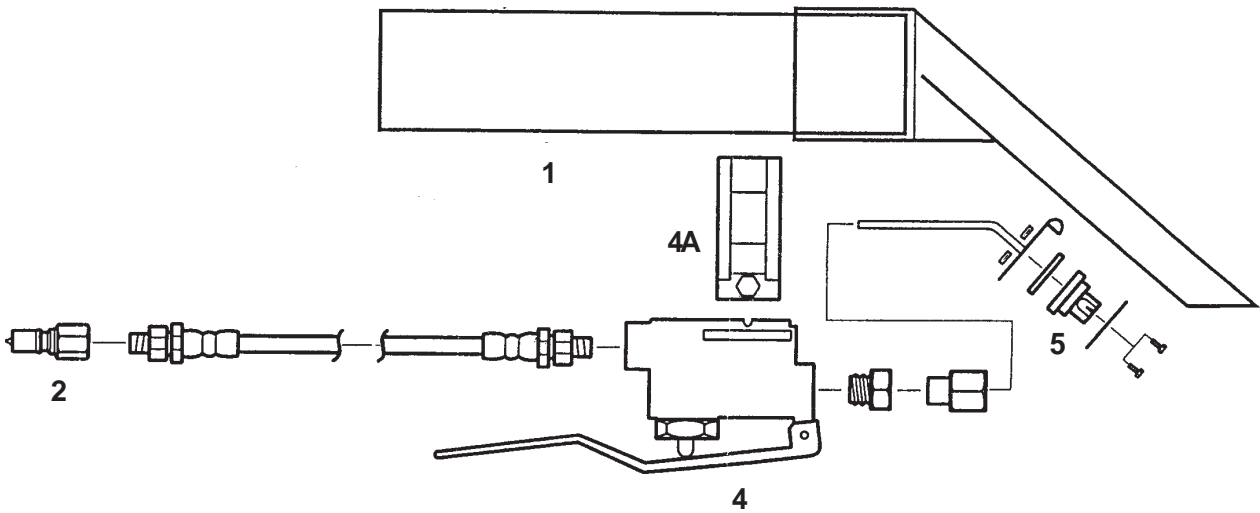

Ref.	Part No.	Description
1	59231A	Hand Tool
2	737140	Quick Connector, 1/8 FPT Male
4	59618A	Valve Assembly
4A	55181A	Valve Hanger
5	54177A	Tee Jet, Plastic Orange

Clarke®
BEXTSPOT™
Vacuum and Solution Hose
Assembly Drawing and Parts List 11/03

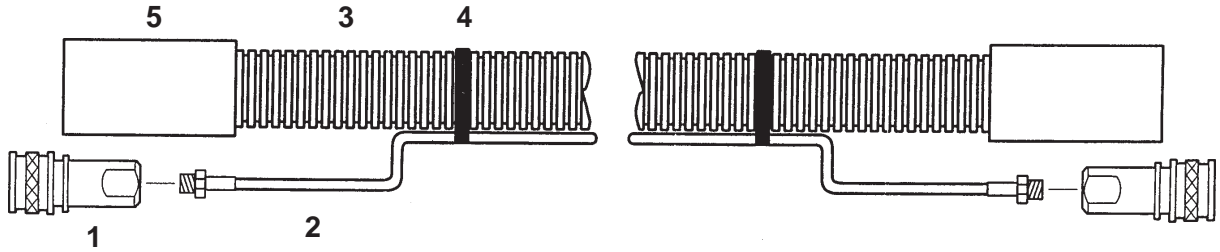

Ref.	Part No.	Description
1	737141	Quick Disconnect Female
2	30495A	1/4" x 10' Vacuum Hose
3	30493A	1 1/4" x 10' Vacuum Hose
4	699202	Cable Ties
5	30494A	Hose Cuff

Authentic Clarke® Products
11/03

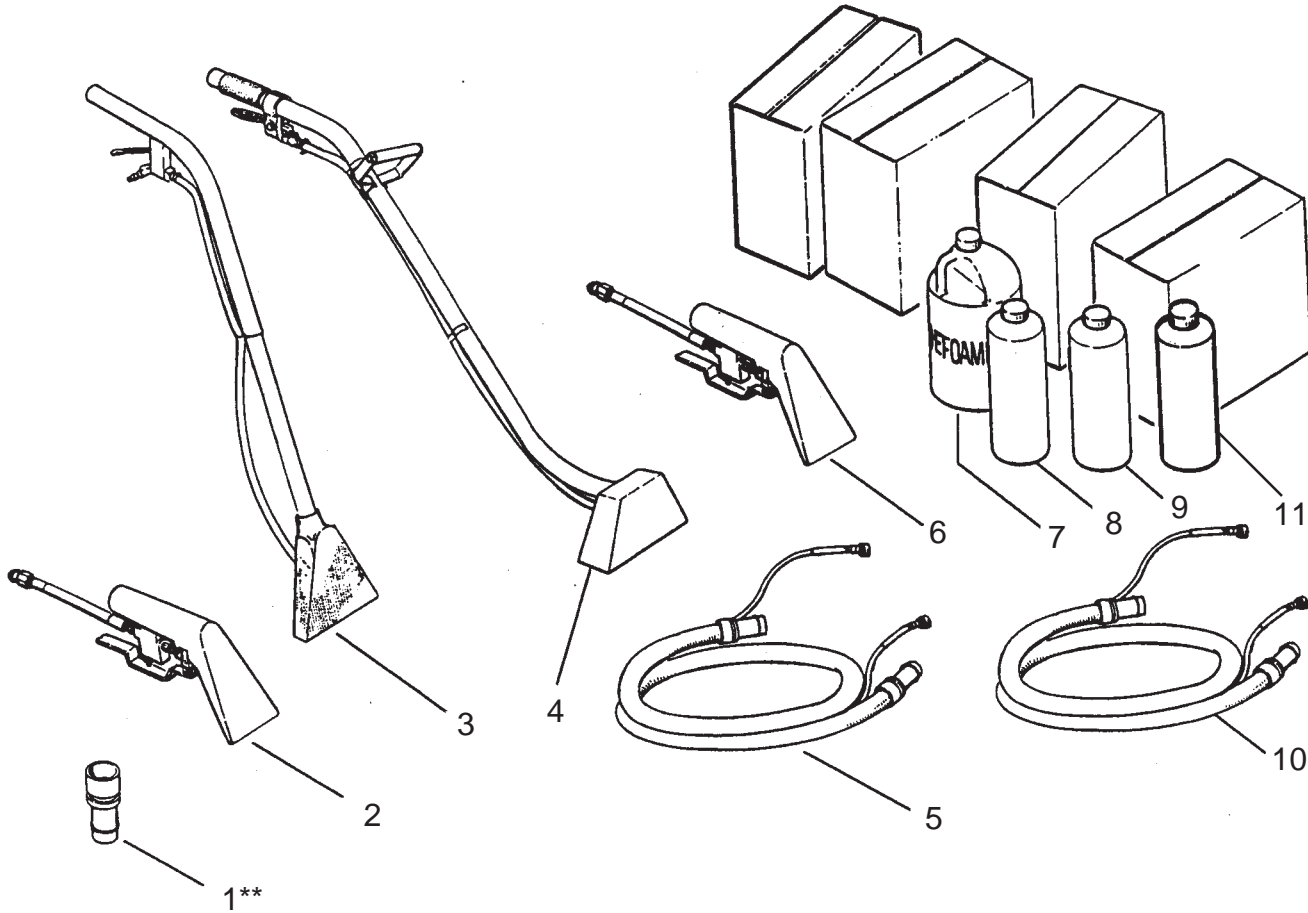

Ref	Part No.	Description	Qty
1	30108A	Adaptor, 2" to 1½"	1
2	59231A	RM-4P Tool Assembly	1
3	59230A	RM-8P Tool Assembly	1
4	59229A	RM-12M Tool Assembly	1
5	59232A	Hide-A- Hose 10'	1
6	59228A	RM-4M Tool Assembly	1
7	398426	Defoamer	*1 case
8	51364A	Odor Digestant	*1 case
9	51362A	Tannin Stain Remover	*1 case
10	55183A	Hide-A-Hose 20'	1
11	51361A	All Purpose Spot Cleaner	*1 case
ASM	55173A	4" Hand Tool & 10' Hose Asm.	1
NI	68204A	Coupler, 1½" Hose Connector	1

* 6 Quart Bottles

**Required to use any accessory

Clarke®
BEXTSPOT™
Wiring Diagram 11/03

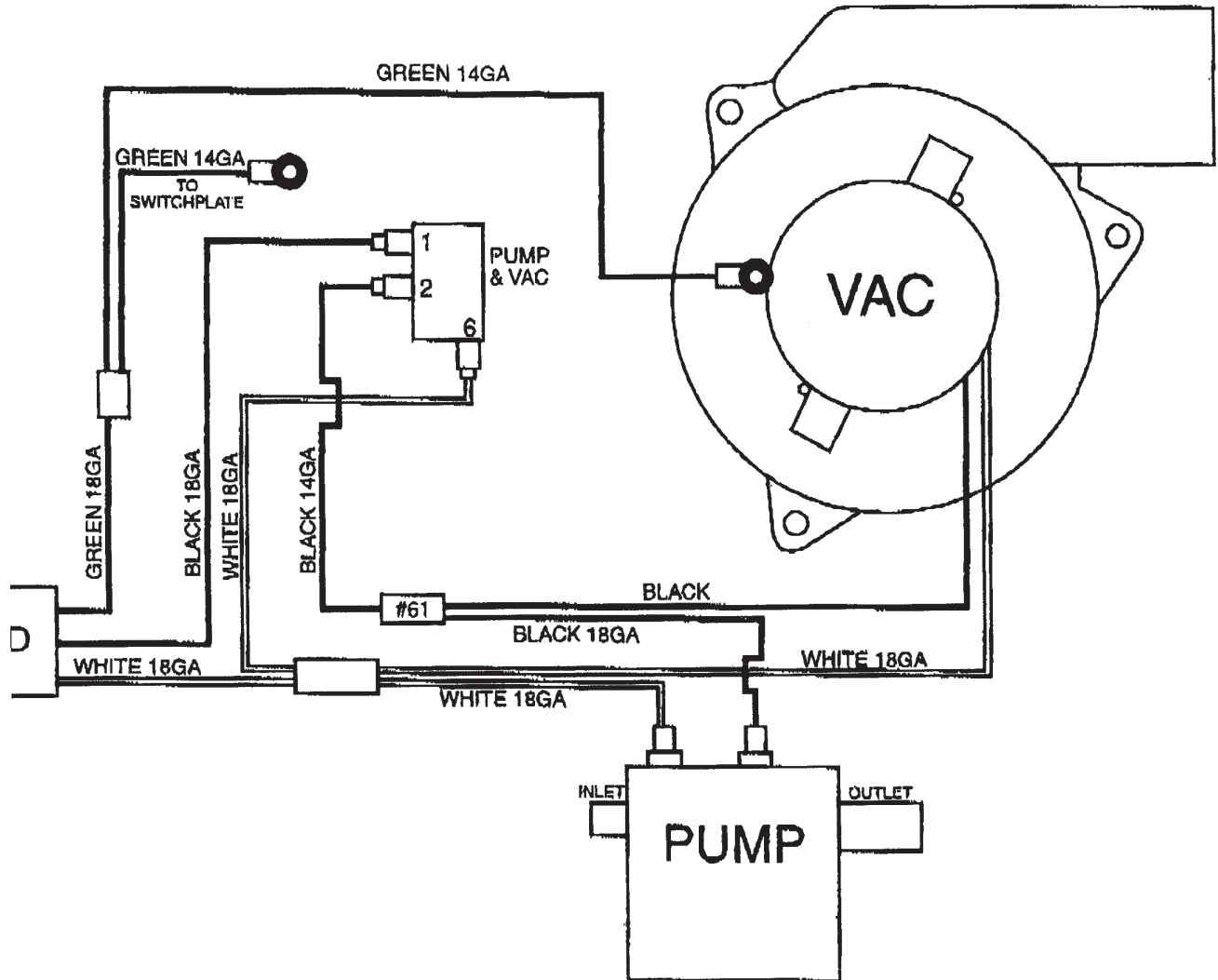

CLARKE PRODUCT SUPPORT BRANCHES

U. S. A. Locations

PRODUCTION FACILITIES

Clarke®, Springdale, Arkansas
2100 Highway 265
Springdale, Arkansas 72764
(479) 750-1000
Customer Service - 1-800-253-0367
Technical Service - 1-800-356-7274

American Lincoln®, Bowling Green, Ohio 43402
1100 Haskins Road

SERVICE FACILITIES

Clarke®, Elk Grove, Illinois 60007
2280 Elmhurst Road
(847) 956-7900

Clarke®, Denver, Colorado 80204
1955 West 13th Ave.
(303) 623-4367

Clarke®, Houston, Texas 77040
7215 North Gessner Road
713-937-7717

SERVICE AND SALES FACILITY

American Lincoln® / Clarke, Madison Heights,
Michigan 48071-0158
29815 John R.
(810) 544-6300

American Lincoln® / Clarke, Marietta, Georgia 30066
1455 Canton Road
(770) 973-5225

Clarke®

Clarke American Sanders

A.L. Cook

Customer Service Headquarters and Factory
2100 Highway 265
Springdale, Arkansas 72764
(479) 750-1000

Technical Service
1-800-356-7274

European Locations

PRODUCTION FACILITIES

ALTO Danmark A/S, Aalborg
Blytaekervej 2
DK-9000 Aalborg
+45 72 18 21 00

ALTO Danmark A/S, Hadsund
Industrikvarteret
DK-9560 Hadsund
+45 72 18 21 00

SALES SUBSIDIARIES

ALTO US - Canada, Ontario (Canada)
4080 B Sladeview Crescent Unit 1
Mississauga, Ontario L5L 5Y5
(905) 569 0266

ALTO Overseas Inc., Sydney (Australia)
1B/8 Resolution Drive
Caringbah NSW 2229
+61 2 9524 6122

ALTO Cleaning Systems Asia Pte Ltd., Singapore
No. 17 Link Road
Singapore 619034
+65 268 1006

ALTO Deutschland GmbH, Bellenberg (Germany)
Guido-Oberdorfer-Straße 2-8
89287 Bellenberg
+49 0180 5 37 37 37

ALTO Cleaning Systems (UK) Ltd., Penrith
Gilwilly Industrial Estate
Penrith
Cumbria CA11 9BN
+44 1768 868 995

ALTO France S.A. Strasbourg
B.P. 44, 4 Place d'Ostwald
F-67036 Strasbourg
Cedex 2
+33 3 8828 8400

ALTO Nederland B.V.
Postbus 65
3370 AB Hardinxveld-Giessendam
The Netherlands
+31 184 677 200

ALTO Sverige AB, Molndal (Sweden)
Aminogatan 18
Box 4029
S-431 04 Molndal
+46 31 706 73 00

ALTO Norge A/S, Oslo (Norway)
Bjornerudveien 24
N-1266
+47 2275 1770

Clarke® U.S. LIMITED WARRANTY

This Clarke Industrial Commercial Product is warranted to be free from defects in materials and workmanship under normal use and service for a period of one year from the date of purchase, when operated and maintained in accordance with Clarke's Maintenance and Operations instructions.

This warranty is extended only to the original purchaser for use of the product. It does not cover normal wear parts such as electrical cable, rubber parts, hoses and motor brushes.

If difficulty develops with the product, you should:

- (a). Return the product to the nearest Clarke repair location. Transportation charges to and from the repair location must be prepaid by the purchaser.
- (b). Clarke will repair the product and or replace any defective parts without charge within a reasonable time after receipt of the product.

Clarke's liability under this warranty is limited to repair of the product and/or replacement of parts and is given to purchaser in lieu of all other remedies, including INCIDENTAL AND CONSEQUENTIAL DAMAGES.

THERE ARE NO EXPRESS WARRANTIES OTHER THAN THOSE SPECIFIED HEREIN. THERE ARE NO WARRANTIES WHICH EXTEND BEYOND THE DESCRIPTION OF THE FACE HEREOF. NO WARRANTIES, INCLUDING BUT NOT LIMITED TO WARRANTY OF MERCHANTABILITY, SHALL BE IMPLIED.

**Clarke reserves the right to make changes or improvements to its machine without notice.
Always use genuine Clarke Parts for repair.**

Clarke®

**2100 Highway 265
Springdale, Arkansas, 72764**