

Clarke[®]

American Sanders

**Operator's
Manual**

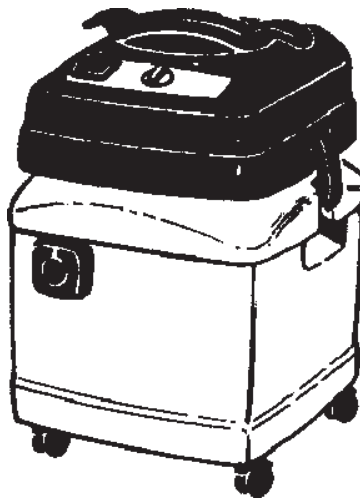

**C.A.V. 15
CLARKE-AMERICAN
Vacuum 15 Gallon**

READ THIS BOOK

This book has important information for the use and safe operation of this machine. Failure to read this book prior to operating or attempting any service or maintenance procedure to your Clarke American Sanders machine could result in injury to you or to other personnel; damage to the machine or to other property could occur as well. You must have training in the operation of this machine before using it. If your operator(s) cannot read English, have this manual explained fully before attempting to operate this machine.

All directions given in this book are as seen from the operator's position at the rear of the machine.

For new books write to: Clarke[®], 2100 Highway 265, Springdale, Arkansas 72764

Table of Contents

Important Safety Instructions	3
Specifications and Accessories	5
Grounding Instructions	6
How To Assemble the Machine	7
Machine Operation	7
Maintenance and Repair	9
Troubleshooting	10
 Section II Parts and Service Manual	
Assembly Drawing for C.A.V. 15 Gallon	12
Parts List	13

IMPORTANT SAFETY INSTRUCTIONS



WARNING



AVERTISSEMENT



ADVERTENCIA



DANGER:

Failure to read and observe all **DANGER** statements could result in severe bodily injury or death. Read and observe all **DANGER** statements found in your Owner's Manual and on your machine.



WARNING:

Failure to read and observe all **WARNING** statements could result in injury to you or to other personnel; property damage could occur as well. Read and observe all **WARNING** statements found in your Owner's Manual and on your machine.



CAUTION:

Failure to read and observe all **CAUTION** statements could result in damage to the machine or to other property. Read and observe all **CAUTION** statements found in your Owner's Manual and on your machine.





WARNING: To reduce the risk of fire, electric shock, or injury:

1. Do not leave machine when plugged in. Unplug from outlet when not in use and before servicing.
2. To reduce the risk of electric shock use indoors only.
3. Do not allow to be used as a toy. Close attention is necessary when used by or near children.
4. Use only as described in the manual. Use only manufacturer's recommended attachments.
5. Do not use with damaged cord or plug. If machine is not working as it should, has been dropped, damaged, left outdoors, or dropped into water, return it to a service center.
6. Do not pull or carry by cord, use cord as a handle, close a door on cord, or pull cord around sharp edges or corners. Do not run machine over cord. Keep cord away from heated surfaces.
7. Do not unplug by pulling on cord. To unplug, grasp the plug, not the cord.
8. Do not handle plug or machine with wet hands.
9. Do not put any object into openings. Do not use with any opening blocked; keep free of dust, lint, hair and anything that may reduce air flow.
10. Keep hair, loose clothing, fingers, and all parts of body away from openings and moving parts.
11. The following materials must not be picked up with the machine: Hot materials (glowing cigarettes, hot ashes, etc.); Inflammable, explosive or aggressive fluids (e.g. gasoline, solvents, acids, alkalines, etc.); Inflammable, explosive dusts (e.g. magnesium or aluminum dust, etc.).
12. Do not use without dust bag and/or filters in place. Use the machine only with an undamaged filter element.
13. Turn off all controls before unplugging.
14. Use extra care when cleaning on stairs.
16. Connect to properly grounded outlet. See "Grounding Instructions".

SAVE THESE INSTRUCTIONS

 **DANGER:** Failure to read the Owner's Manual prior to operating or attempting any service or maintenance procedure to your machine could result in injury to you or to other personnel; damage to the machine or to other property could occur as well. You must have training in the operation of this machine before using it. If your operator(s) cannot read English, have this manual explained fully before attempting to operate this machine.

 **DANGER:** Operating a machine that is not completely or fully assembled could result in injury or property damage. Do not operate this machine until it is completely assembled. Inspect the machine carefully before operation. Use only as described in this manual. Use only Wap Technology's recommended attachments and replacement parts.

 **WARNING:** Operating a machine without observing all labels, decals, etc., could result in injury or damage. Read all machine labels before attempting to operate the machine. Make sure all of the labels are attached or fastened to the machine. Get replacement labels and decals from your Wap Technology distributor.

 **WARNING:** Before connecting any appliance to the appliance plug socket, the machine must always be switched off. If appliances are connected to the appliance plug socket, ensure that these appliances are also switched off when being connected to the appliance plug socket. See "Appliance Plug Socket" in the "Grounding Instructions" section in of this manual.

 **CAUTION:** Making technical modifications to the machine could endanger your safety. Do not make any technical modifications to the machine.

 **CAUTION:** Never spray the top section of the machine with water. Can cause danger to persons or danger of short circuits.

 **CAUTION:** Wrap cord around handle when machine is not in use. Use caution not to run over cord while machine is in use.

 **CAUTION:** This machine is not suitable for picking up health endangering dust.

 **CAUTION:** If foam/liquid comes out, switch off immediately.

SPECIFICATIONS & ACCESSORIES

Model	C.A.V. 15
Voltage	120 V
Frequency	60 Hz
Power	1200 Watts
Connected load for appliance plug socket	600 Watts
Volume Flow (air)	120 CFM
Static Water Lift	90"
Filter Surface Area 3-Stage	2,212 sq. inches
Sound Level	58 db(A)
Cord Length	22'
Tank Volume	15 gal.
Width	17"
Depth	17"
Height	26"
Weight	33 lbs.
Order # for bag-type filter elements (pack of 5 elements)	52850A
Order # for filter element	29747
H.E.P.A. Filter	40181
Cloth Filter Liner / Washable	61086A -Dacron 61281A-Sateen
Filter Element Cover	11801
Squeegee Floor Tool	5149
Replacement Squeegee Blades	6114 (set of 2)

NA = Not available

GROUNDING INSTRUCTIONS

This appliance must be grounded. If it should malfunction or breakdown, grounding provides a path of least resistance for electric current to reduce the risk of electric shock. This appliance is equipped with a cord having an equipment-grounding conductor and grounding plug. The plug must be plugged into an appropriate outlet that is properly installed and grounded in accordance with all local codes and ordinances.

- WARNING:** Improper connection of the equipment-grounding conductor can result in a risk of electric shock. Check with a qualified electrician or service person if you are in doubt as to whether the outlet is properly grounded. Do not modify the plug provided with the product - if it will not fit the outlet, have a proper outlet installed by a qualified electrician.

This appliance is for use on a nominal 120-volt circuit and has a ground plug that looks like the plug illustrated in figure 1. Make sure that the appliance is connected to an outlet having the same configuration as the plug. No adapter should be used with this appliance.

- WARNING:** To prevent possible electric shock, protect the machine from rain. Keep the machine in a dry building.
- WARNING:** To prevent possible electric shock, always use a 3-wire electrical system connected to the electrical ground. For maximum protection against electrical shock, use a circuit that is protected by a ground fault circuit interrupter. Consult your electrical contractor.
- WARNING:** Do not cut, remove or break the ground pin. If the outlet does not fit the plug, consult your electrical contractor.
- WARNING:** Have worn, cut or damaged cords replaced by an authorized service person.

EXTENSION CORDS

Use only an approved extension cord with three conductors, a plug with three terminals, and a connector body with three holes. The machine has a power cord with wire size 16 AWG (AWG means American Wire Gauge).

- WARNING:** If you use an extension cord, use an extension cord with minimum wire size 14 AWG. Do not use an extension cord longer than 50 feet. Do not join two extension cords.

APPLIANCE PLUG SOCKET

Before connecting any appliance to the appliance plug socket, the machine must always be switched off. If appliances are connected to the appliance plug socket, ensure that these appliances are also switched off when being connected to the appliance plug socket.

- CAUTION:** The operating instructions and the safety precautions contained therein must be observed when using appliances connected to the appliance plug socket of the machine.

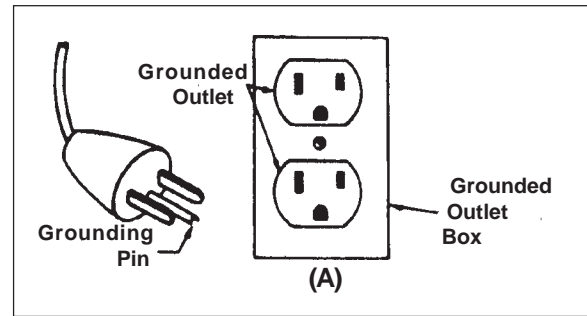

Figure 1

HOW TO ASSEMBLE THE MACHINE

CAUTION!

On delivery, the accessories - are lying in the tank and must be removed before the machine is used for the first time. See figure 2.

To assemble the machine, remove the machine top section:

The power cord must not yet be inserted into a plug socket.

1. Open the retaining clamps and lift off the machine top section (Figure 3).
2. Place a bag-type filter into the tank as described in the instructions printed on the filter.
3. Fit the machine top section back on the tank, and close the retaining clamps.
4. Connect the suction hose. The "Wap Multifit" enables any Wap Technology suction hoses (27, 32, 36, 50 mm diameter) to be connected to the machine (Figure 4).

MACHINE OPERATION

Picking Up Dry Substances

Before picking up dry substances, the bag-type filter should always be installed in the tank. It is then easy to dispose of the material picked up and the service life of the main filter element is significantly increased. Dry cleaning without bag-type filter is also possible.

WARNING: Inflammable substances must not be picked up with the machine!

After picking up liquids, the filter element is damp. Damp filter elements can clog more quickly when dry substances are picked up. For this reason, the filter element should be dried or replaced before picking up any dry substances.

Picking Up Liquids

Before picking up liquids, the bag-type filter must always be removed from the tank.

WARNING: Inflammable liquids must not be picked up with the machine!

If foaming is observed, stop work immediately and empty the tank.

Switching On The Machine (C.A.V 15)

Turn the switch to position "I" (Figure 3).

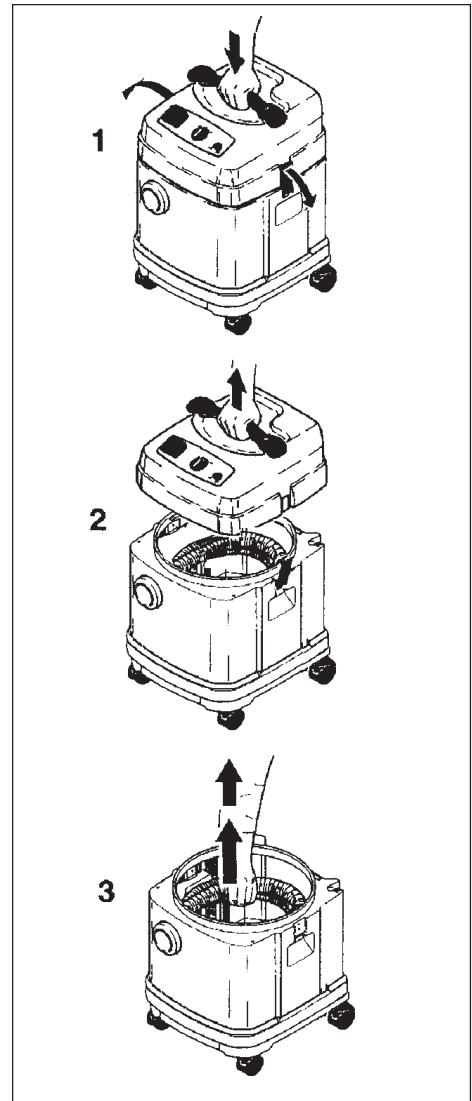

Figure 2



Figure 3

MACHINE OPERATION

Changing The Bag Type Filter

1. Close the bag-type filter sleeve with the slide (Figure 4).
2. Pull the bag-type filter sleeve off the inlet fitting.
3. Dispose of the used bag-type filter in accordance with the local waste disposal regulations.
4. Place a new bag-type filter into the tank as described in the instructions printed on the filter.

IMPORTANT!

Push the bag-type filter sleeve completely onto the inlet fitting.

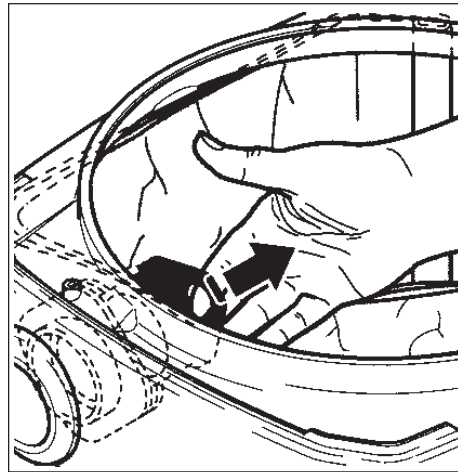

Figure 4

Replacing The Filter Element

1. Switch off the machine and pull the plug of the power cord out of the plug socket.
2. Remove the machine top section from the dirt tank and place to one side with the filter element facing upwards (Figure 5).
3. Unscrew the filter retaining nut (1) and remove together with the retaining washer (2).
4. Pull off the filter element (3).
5. Push on a new filter element.
6. Fit the filter retaining washer and tighten the retaining nut.
7. Dispose of the used filter element in accordance with the local waste disposal regulations.

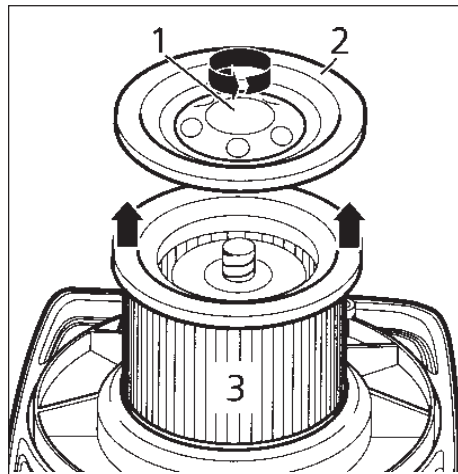

Figure 5

MAINTENANCE AND REPAIR

CAUTION: Before cleaning and servicing the machine, always remove the power cord.

Carry out only maintenance operations described in these operating instructions. Use only original Wap Technology spare parts.

CAUTION: Do not make any technical modifications to the machine. Your safety could be endangered as a result!

For all other maintenance and repair work, please contact and authorized Wap Technology Service department.

Clarke[®]

American Sanders

Division of
ALTO[®]

C.A.V. 15

Wet/Dry Vacuum

Section II

Parts and Service

(70641B)

**Clarke®
American Sanders
C.A.V. 15
Assembly Drawing 7/05**

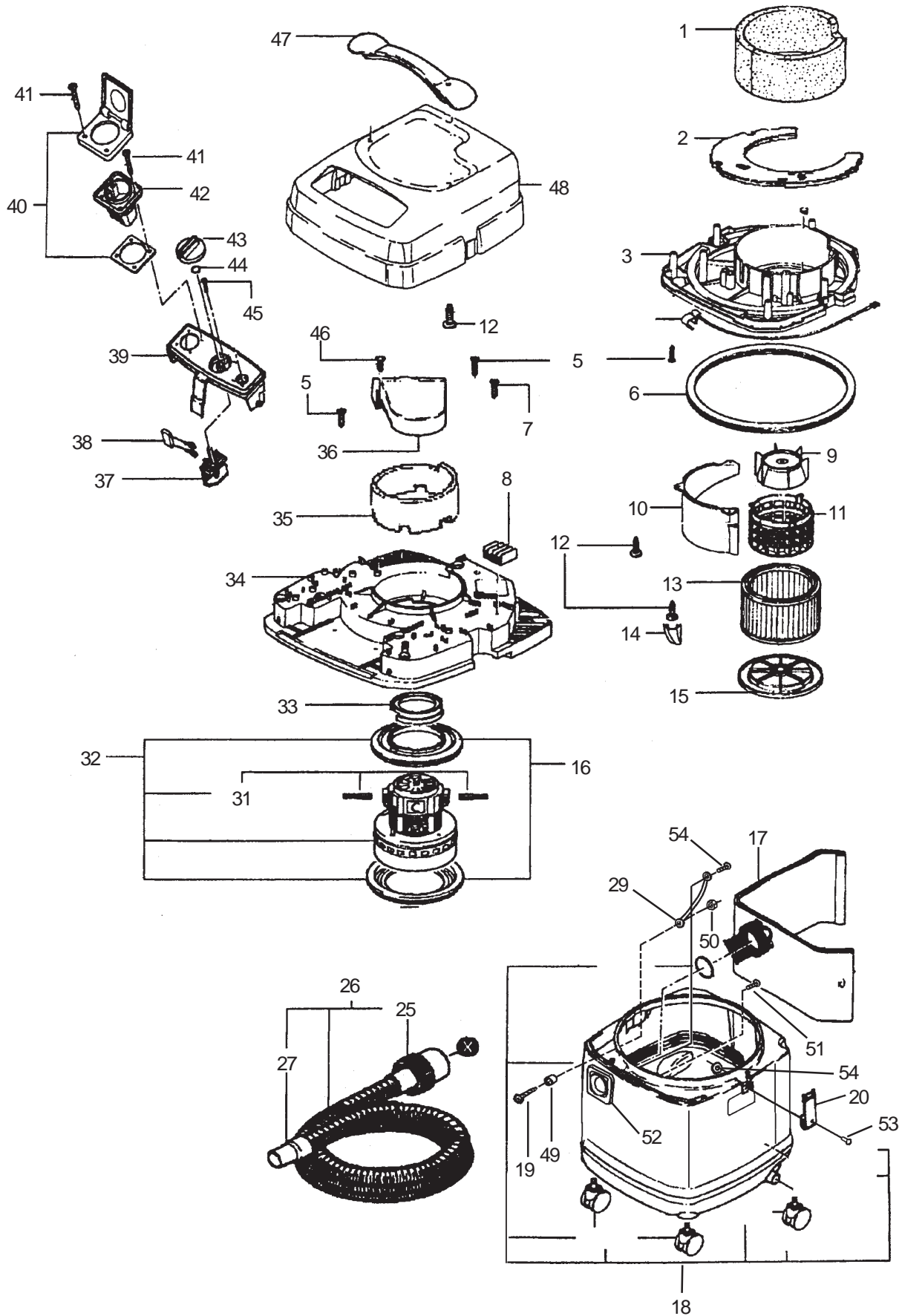

Clarke®
American Sanders
C.A.V. 15
Assembly Parts List 7/05

Ref.	Part No.	Description	Qty
1	47014	Ring, Foam Rubber	1
2	47006	Silencer	1
3	44239	Lower Housing, SQ.	1
4	26792	Ground Contact SQ. 10	1
5	11253	Screw, 50mm x 20mm	1
6	11222	Packing Ring, Gasket	1
7	11256	Screw, 35mm x 18mm	1
8	48421	Terminal Block	1
9	11835	Float, Short	1
10	45692	Deflector	1
11	46418	Filter Frame	1
12	11565	Screw, 50 x 18	1
13	29747	Fleece Filter, SQ.	1
14	47025	Covering	1
15	29753	Filter Holder Disc, SQ.	1
16	31972	Rubber Seal, Vac Motor	2
17	52850A	Filter Bags, 15 Gallon	
18	100006	Canister, SQ 15 Blue	1
19◆	80154A	Screw, ¼ -20 x 1½ Brass	1
20◆	19880	Clamp	2
23	59977A	Wheel	4
24	46298	Cater Swivel	
25	15102	Swivel, Hose	1
26◆	10330A	Suction Hose 1.5" x 25' (Includes 25,27)	1
27	11597	Hose Cuff	1
29◆	40536A	Lead, Ground Antistatic	1
31	26774	Carbon Brush (Pair)	1
32	26785	Vac, Motor Complete	1
33	47035	Rubber Seal, Vac Motor	1
34	44240	Upper Housing, SQ	1
35	47015	Motor Ring	1
36	25700	Air Diverter, SQ.	1
37	29989	Rotary Switch, SQ.	1
38	48338	Screening Filter	1
39	29755	Control Panel	1
40	46297	Plug Cover	1
41	46248	Screw	1
42	49267	Plug Socket	1
43	243606	Knob, SQ.	1
44	9868	O Ring 10 x 2.5 mm	1
45	18274	Screw	
46	11254	Screw	
47	26801	Handle	1
48	26803	Cover SQ.	1
49◆	30174A	Spacer, Antistatic	1
50◆	920349	Nut, ¼ - 2	1
51◆	11565	Screw, 50 x 18	4
52◆	11180	Inlet	1
53◆	80299A	Rivet	4
54◆	80219A	Washer	4
NI	61086A	Filter Bag, Dacron	1
NI	61281A	Filter Bag, Sateen	1
NI	639804	Curved Wand, Chrome (Not illustrated)	1

CLARKE PRODUCT SUPPORT BRANCHES

U. S. A. Locations

PRODUCTION FACILITIES

Clarke®, Springdale, Arkansas
2100 Highway 265
Springdale, Arkansas 72764
(479) 750-1000
Customer Service - 1-800-253-0367
Technical Service - 1-800-356-7274

American Lincoln®, Bowling Green, Ohio 43402
1100 Haskins Road

SERVICE FACILITIES

Clarke®, Elk Grove, Illinois 60007
2280 Elmhurst Road
(847) 956-7900

Clarke®, Denver, Colorado 80204
1955 West 13th Ave.
(303) 623-4367

Clarke®, Houston, Texas 77040
7215 North Gessner Road
713-937-7717

SERVICE AND SALES FACILITY

American Lincoln® / Clarke, Madison Heights,
Michigan 48071-0158
29815 John R.
(810) 544-6300

American Lincoln® / Clarke, Marietta, Georgia 30066
1455 Canton Road
(770) 973-5225

SALES AND DISTRIBUTION CENTER

Clarke®, Secaucus, NJ 07094
74 Henry Street
(201) 864-5503

Clarke®
Clarke American Sanders
A.L. Cook
Customer Service Headquarters and Factory
2100 Highway 265
Springdale, Arkansas 72764
(479) 750-1000
Technical Service
1-800-356-7274

European Locations

PRODUCTION FACILITIES

ALTO Danmark A/S, Aalborg
Blytaekkervej 2
DK-9000 Aalborg
+45 72 18 21 00

ALTO Danmark A/S, Hadsund
Industriksvarteret
DK-9560 Hadsund
+45 72 18 21 00

SALES SUBSIDIARIES

Clarke® Canada Ltd., Rexdale Ontario
24 Constellation Ct.
(416) 675-5830

ALTO Overseas Inc., Sydney (Australia)
1B/8 Resolution Drive
Caringbah NSW 2229
+61 2 9524 6122

ALTO Cleaning Systems Asia Pte Ltd., Singapore
No. 17 Link Road
Singapore 619034
+65 268 1006

ALTO Deutschland GmbH, Bellenberg (Germany)
Guido-Oberdorfer-Straße 2-8
89287 Bellenberg
+49 0180 5 37 37 37

ALTO Cleaning Systems (UK) Ltd., Penrith
Gilwilly Industrial Estate
Penrith
Cumbria CA11 9BN
+44 1768 868 995

ALTO France S.A. Strasbourg
B.P. 44, 4 Place d'Ostwald
F-67036 Strasbourg
Cedex 2
+33 3 8828 8400

ALTO Nederland B.V.
Postbus 65
3370 AB Hardinxveld-Giessendam
The Netherlands
+31 184 677 200

ALTO Sverige AB, Molndal (Sweden)
Aminogatan 18
Box 4029
S-431 04 Molndal
+46 31 706 73 00

ALTO Norge A/S, Oslo (Norway)
Bjornerudveien 24
N-1266
+47 2275 1770

Clarke® American Sanders U. S. Warranty

This Clarke American Sanders Industrial/Commercial Product is warranted to be free from defects in materials and workmanship under normal use and service for a period of two years from the date of purchase, when operated and maintained in accordance with Clarke American Sanders's Maintenance and Operations instructions.

This warranty is extended only to the original purchaser for use of the product. It does not cover normal wear parts such as electrical cable, rubber parts, hoses and motor brushes.

If difficulty develops with the product, you should:

(a). Contact the nearest authorized Clarke American Sanders repair location or contact the Clarke American Sanders Service Operations Department, 2100 Highway 265, Springdale, Arkansas, for the nearest authorized Clarke American Sanders repair location. Only these locations are authorized to make repairs to the product under this warranty.

(b). Return the product to the nearest Clarke American Sanders repair location. Transportation charges to and from the repair location must be prepaid by the purchaser.

(c). Clarke American Sanders will repair the product and or replace any defective parts without charge within a reasonable time after receipt of the product.

Clarke American Sanders's liability under this warranty is limited to repair of the product and/or replacement of parts and is given to purchaser in lieu of all other remedies, including INCIDENTAL AND CONSEQUENTIAL DAMAGES.

THERE ARE NO EXPRESS WARRANTIES OTHER THAN THOSE SPECIFIED HEREIN. THERE ARE NO WARRANTIES WHICH EXTEND BEYOND THE DESCRIPTION OF THE FACE HEREOF. NO WARRANTIES, INCLUDING BUT NOT LIMITED TO WARRANTY OF MERCHANTABILITY, SHALL BE IMPLIED. A warranty registration card is provided with your Clarke American Sanders product. Return the card to assist Clarke American Sanders in providing the performance you expect from your new floor machine.

Clarke, 2100 Highway 265, Springdale, Arkansas 72764.

Clarke American Sanders reserves the right to make changes or improvements to its machine without notice.

Always use genuine Clarke American Sanders Parts for repair.

Clarke®

American Sanders

**2100 Highway 265
Springdale, Arkansas, 72764**